



CASCAIDE®

INSTALLATION • OPERATION • MAINTENANCE MANUAL

EMERGENCY FLOOR MOUNTED AND OVERHEAD PIPE MOUNTED SHOWER STATIONS

PRODUCT DESCRIPTION

Emergency Shower Stations designed for floor mounting or horizontal pipe mounting in areas where people may come into contact with hazardous materials.

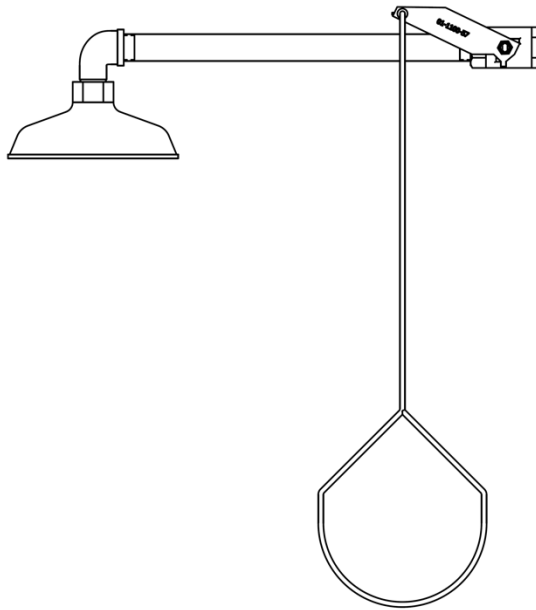

CC1000

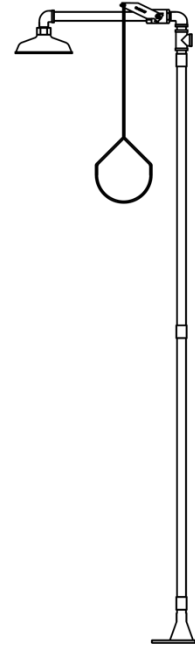

CC1001

ASSEMBLY AND INSTALLATION INSTRUCTIONS

Overhead Showers

1. Locate overhead supply water connection.
2. Verify that the height distance of the overhead supply water connection maintains the shower head in a horizontal position (when installed) between 82" and 96" from the surface on which the user stands.
3. Connect valve to overhead supply water connection using pipe wrench and appropriate pipe sealant.
4. Remove cotter pin and washer from the pull rod and insert the tip through the hole at the end of the shower actuator arm. Tip of pull rod should be on the actuator arm side closest to the overhead piping. Re-attach washer and cotter pin to secure pull rod.
5. Thread ABS Plastic yellow shower head, taking care not to cross thread. Hand tighten until snug. DO NOT OVER TIGHTEN. Do not use a pipe wrench. Pipe sealant or tape is not required or recommended.
6. Test unit for leaks and for proper water flow pattern by activating valve using actuation pull rod.

FIGURE 1

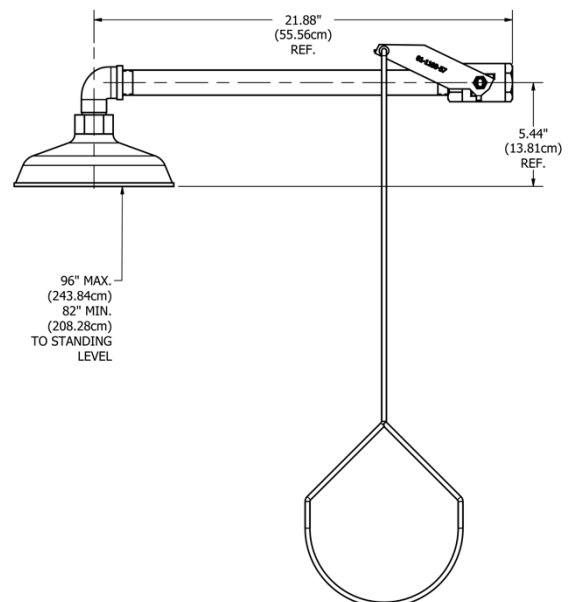

Floor Mounted Shower

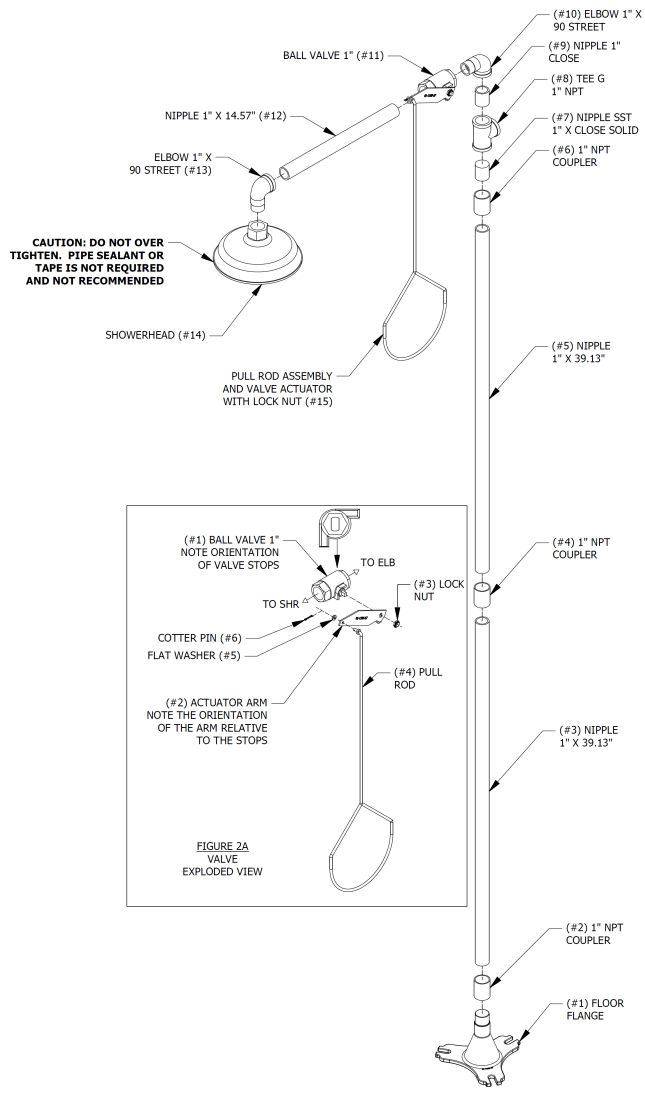

FIGURE 2
FULL EXPLODED VIEW

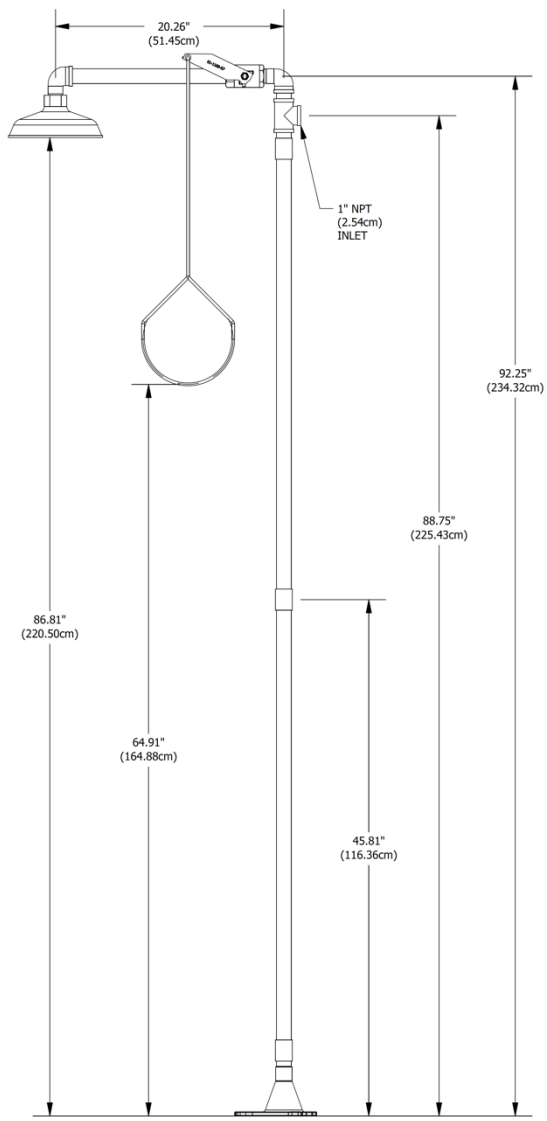

FIGURE 3
MEASUREMENTS

Step 1 – Floor Flange Mounting – Mounting hardware is not included (supplied by others).

CAUTION: CHECK FOR ADEQUATE FLOOR STRENGTH.

- Concrete:** Secure the floor flange using three (3) expansion anchors or equal type anchors. NOTE: If a concrete base is required ensure raised area is no more than 2" from standing level.
- Metal:** Secure floor flange using three (3) 1/2"-13 UNC machine bolts and nuts for thick metal surface (drill and tap thick metal surface), or three (3) 1/2"-13 bolts and nuts for thin metal surface. Bolts should be long enough to allow at least a 1/2" bolt clearance for nut attachment.
- Wood:** Secure floor flange using three (3) 1/2" x 3" lag screws.

Step 2 – Assembly

NOTES:

1. The use of a pipe wrench and appropriate pipe sealant are required for proper attachment of each component, unless otherwise noted.
2. If an obstruction exists which may prevent assembly of the overhead section to the flange, complete this step first before securing the floor flange to the floor (Step 1)
3. When floor flange is secure, check flange to ensure correct installation and no movement of the flange is present.

4. Pipe lengths can be verified using pipe guide provided on side of shipping carton.
5. Assemble components in order based on sequence numbers provided on **Figure 2 and 2A**, ensuring that the inlet tee (#8) is orientated not to impede the activation of the shower valve
6. Before attaching the pull rod to the valve actuator, remove the cotter pin and washer from the rod.
7. Test unit for leaks and for proper water flow pattern by activating valve using the pull rod.
8. See **Figure 2A** for recommended orientation of the valve and actuator.
9. See **Figure 3** for final mounting recommended measurement.

GENERAL INFORMATION

Following are requirements of ANSI Z358.1 for Emergency Eyewash and Shower Equipment. A complete copy of this standard may be purchased from the international Safety Equipment Association.

1. Unit shall be installed in accordance with the manufacturer's instructions and acceptable plumbing practices.
2. The height of the shower head shall be not less than 208.28 cm (82 inches) or more than 243.84 cm (96 inches) from the surface on which the user stands.
3. The unit shall be connected to a system capable of supplying adequate flushing fluid to meet the flow requirements of each component operating simultaneously. The supply line shall provide an uninterrupted supply of potable water at recommended minimum 0.207 megapascal (30 pounds per square inch) and maximum 0.552 megapascal (80 pounds per square inch) of flow pressure.
4. Where the possibility of freezing conditions exists, equipment shall be protected from freezing or freeze-protected equipment shall be installed.
5. When a shower is installed, it shall be tested in accordance with the following procedures:
 - a. With the unit correctly connected to the water source and the valve(s) closed, visually check the piping connection for leaks.
 - b. Open the valve to the full open position. The valve shall remain open without requiring further use of the operator's hands.
 - c. With the valve in the "full on" position, measure the diameter of the spray pattern. It shall be a minimum of 50.80 cm (20 inches) at 152.40 cm (60 inches) above the standing surface. The center of the spray shall be at least 40.64 cm (16 inches) from any obstructions.
6. Shower units shall be in accessible locations that require no more than 10 seconds travel time from the farthest hazard.
7. Each unit location shall be identified with a highly visible sign. The area around the unit shall be well lit.
8. Plumbed units shall be inspected annually for proper operation to ensure compliance to ANSI Z358.1 standard.

OPERATION & MAINTENANCE

1. Plumbed units shall be activated weekly to flush lines and verify proper flow pattern and volume.
2. If freeze or scald protection valve is included with your unit, the valves should be inspected each year, and cycled before hot or cold weather sets in.
3. Test records should be maintained verifying compliance with testing procedures.

TRAINING

All employees who might be exposed to hazardous material shall be instructed in the location and proper use of emergency shower and eye/face wash units. Experiences have shown that initial first-aid treatment for irritants should be to wash the eyes and face for 15 minutes prior to medical treatment. It is important to hold the eyelids open and roll the eyes so water will flow on all surfaces and in the folds surrounding the eyes.

PROPOSITION 65

WARNING: This product can expose you to BPA, which is known to the State of California to cause birth defects or other reproductive harm. For more information go to www.P65Warnings.ca.gov.

WARRANTY STATEMENT

THE SELLER HEREBY DISCLAIMS ALL WARRANTIES EXPRESSED OR IMPLIED INCLUDING BUT NOT LIMITED TO WARRANTIES OF MERCHANTABILITY, FITNESS FOR A PARTICULAR PURPOSE, AND NON-INFRINGEMENT OF THIRD-PARTY RIGHTS, EXCEPT AS HEREINAFTER PROVIDED.

The Seller warrants that for one year from the date of purchase of any of the Seller's products, the product will be free of defects in materials and workmanship if properly used and cared for or cleaned under normal conditions in accordance with the Seller's use and care instructions and properly installed, if applicable, in accordance with the Seller's installation instructions. With respect to the product, the Seller's only obligation and purchaser's exclusive remedy under this warranty is to repair or replace such product; provided that:

1. The Seller is notified of the defect within one year of shipment, and
2. The product is determined by the Seller to be defective.

The Seller requires proof of original ownership as proof of warranty coverage, and the Seller must receive any claim under this Limited Warranty within one year of purchase of the product.

NOTWITHSTANDING ANYTHING TO THE CONTRARY CONTAINED HEREIN, THE SELLER SHALL NOT BE LIABLE FOR LOSS, DAMAGE, OR EXPENSE ARISING DIRECTLY OR INDIRECTLY AS A CONSEQUENCE OF USE OF THE EQUIPMENT WITH OTHER PRODUCTS OR FROM ANY OTHER CAUSE, INCLUDING ANY CONSEQUENTIAL, INCIDENTAL, SPECIAL OR EXEMPLARY DAMAGES, EXCEPT FOR THE SELLER'S OBLIGATION TO REPAIR OR REPLACE DEFECTIVE PRODUCTS AS EXPRESSLY PROVIDED IN THIS STATEMENT.

Replacement parts purchased from the Seller are warranted for one year following the shipment of such replacement part, or until the expiration of the warranty period for the product, whichever is less. No warranty is given in connection with products that are altered without the Seller's expressed written consent. The same warranty limitations and the obligations of the Seller as set out herein above shall apply to replacement parts.

The Seller's total liability arising out of this warranty (including, but not limited to, warranty claims) regardless of forum and regardless of whether such action or claim is based on tort, contract or otherwise will not exceed the total purchase price of the product.



6825 W. Sam Houston Pkwy. N
Houston, Texas 77041
1-800-283-6266

customerservice@cascaide.com
<http://www.cascaide.com>